

FUME HOOD INSTALL SHEET 1 STEPS 1-5A

IF REQUIRED PIPE UP TO WORK SURFACE AND CLEAN SURFACES BEFORE FUME HOOD MOUNTING.

STUB EITHER FLUSH WITH TOP OR JUST ABOVE. BE CAREFUL NOT TO GO TOO HIGH IT WILL BE HARDER TO GET THE FUME HOOD IN PLACE

GLUE AND FASTEN EPOXY OR STAINLESS STEEL FUME HOOD TOP IN PLACE MAKE SURE IT IS SECURE

1

STEP 1

ROUGH IN PLUMBING AND POWER WHERE REQUIRED

SECURE BASE CABINETS IN PLACE

2

STEP 2

SET CABINETS AND WORK SURFACES SEE INSTALL DATA

USE A LIFT OR OTHER DEVICE TO HELP GET THE FUME HOOD TO WORK SURFACE HEIGHT THEN SLIDE THE UNIT INTO PLACE. BE CAREFUL OF PLUMBING

PRIOR TO LIFTING HOOD INTO PLACE REMOVE WOOD SKID AND BLOCKING MATERIAL. ALSO REMOVE SIDE PANELS PER STEP 3.

5

LIFT HOOD TO DECK HEIGHT SLIDE IN PLACE

ISO VIEW

BEFORE SIDE PANELS CAN BE REMOVED.

- REMOVE TWO SELF THREADING SCREWS LOCATED ON SIDE PANEL TOP. USE A PHILLIPS DRIVER / CLUTCH DRILL IF POSSIBLE.
- LOOSEN BOLT SECURING POST FRONT TO FRAME TO SIDE PANEL 1/4-20 USE APPROPRIATE TOOLS OR REMOVE COMPLETELY.
- THE BOTTOM BOLT SHOULD BE LOOSE BUT CAN BE ACCESSED THROUGH THE INTERIOR ACCESS PANEL. YOU ARE NOW READY TO REMOVE THE PANEL.
- PULL UP THEN PULL OUT TO RELEASE THERE IS A BOTTOM CLIP WELDED TO THE SIDE PANEL. ONCE YOU PULL UP IT WILL RELEASE.

WHEN REMOVING LOOSEN BOLT IN TOP POST FRONT AND PULL SIDE PANEL STRAIT UP THEN OUT TO RELEASE

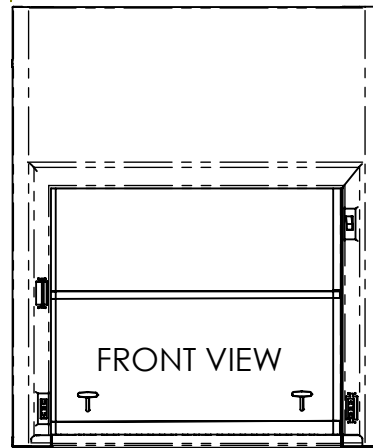

4

STEP 4 REMOVE OUTER SIDE PANELS BOTH SIDES.

REMOVE TWO SELF TAPING SCREWS BOTH SIDES

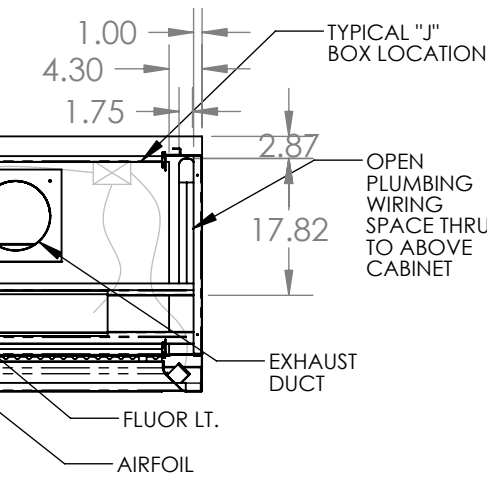

FRAME HAS LASERED HOLES USE AS A GUIDE 2 PLCS BOTH SIDES. DRILL INTO TOP 9/64" THEN USE #8 X 5/8" S.S. SHEET METAL SCREW AND SECURE FUME HOOD TO DECK. BOTH SIDES TYPICAL. "NOTE USE A MASONARY BIT TO DRILL EPOXY"

MAKE SURE HOOD IS PUSHED TIGHT TO WORK SURFACE BEFORE SECURING. SQUARE UNIT UP AND MAKE SURE SASH OPERATES SMOOTHLY.

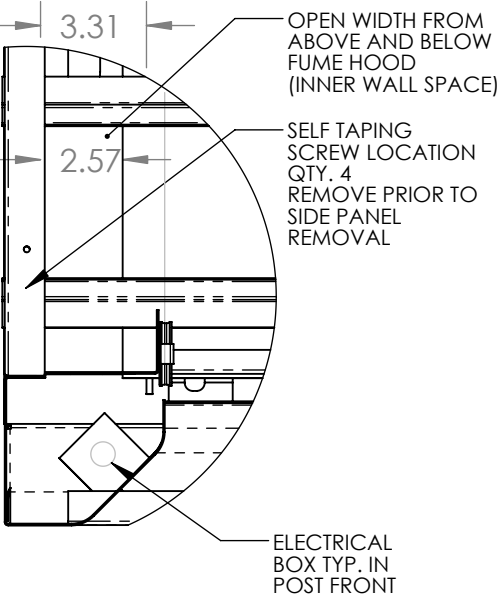

DETAIL B SCALE 1 : 6

"J" BOX THERE ARE TWO SIZES TO ACCOMADTE ADDED FIXTURE ASSEMBLIES STOCK ALLOWS FOR 9 CONNECTIONS WHILE THE LARGER BOX ADDS 3 MORE.

MAIN POWER SINGLE POINT OF CONNECTION INTO "J" BOX BOX OPTIONS AVAILABLE

TYPICAL FLEX METAL CONDUIT OR HARD PIPE IF X-PROOF

REMOVABLE ACCESS PANEL INTERNAL TYP. (4) 1/4-20 NYLON SCREWS

INTERIOR FIXTURE OUTLET LOCATIONS

FRAME MOUNTING HOLES 4 PLCS 2 EA. SIDE USE S.S. #8 SHEET METAL SCREW OR A HI-LO TYPE FASTENER MINIMUM LENGTH 5/8"

PIPING LOCATION IF PIPING FROM BELOW INTO FUME HOOD REFERENCE ONLY

OPEN PLUMBING WIRING SPACE THRU TO ABOVE CABINET

5A

SCURE HOOD IN PLACE AND START HARD CONNECTIONS

SKID REMOVAL/ UNPACKING BEFORE DECK MOUNTING

3

STEP 1 REMOVE ALL PLASTIC WRAP, TAPE, BANDING, AND CARD BOARD PROTECTIVE MATRL.

STEP 2 SASH BLOCKING WOOD. REMOVE TWO WOOD SCREWS AND TAPE HOLDING BLOCKING WOOD IN BOTH SIDES OF SASH CHANNEL

STEP 3 WEIGHT BLOCKING WOOD - REMOVE ONLY UNPAINTED WOOD TAPED IN PLACE AT BOTTOM BOTH SIDES. DO NOT REMOVE WEIGHT STOP

STEP 4 TO FINISH UNPACKING - SEE STEP 4 ABOVE FIRST: ONCE THE SIDE PANELS ARE OFF REMOVE TWO WOOD SCREWS BOTH SIDES LOCATED IN THE FUME HOODS FRAME BOTTOM. SCREWS ATTACH FRAME TO SKID.

